

# Stannah Microlift Double Decker

## USER HANDBOOK



### IMPORTANT

Before using your Stannah Microlift, please ensure that you read and familiarise yourself with these instructions.



---

# INDEX

---

Introduction	3
Microlift Operation	
Controls and Calling	4
Safe Operation of Microlift Car Shutter	5
Loading	6
Sending and Unloading	7
Do's and Don'ts	8
Intercom Option	9
Heated Compartment Option	10
Heated Shelf Option	11
Microlift Care	12
Guarantee	13
Troubleshooting	14
Stannah Service Branches	15

---

## For your records:

Microlift Model:

Load capacity (kg):

Serial number:

Date into service:

## Note:

Whilst every effort has been made to ensure the clarity and accuracy of this handbook, Stannah Microlifts cannot be held responsible for damage or injury resulting from negligence or misuse of the Microlift.

---

# INTRODUCTION

---

## Important - please read

Thank you and congratulations on purchasing a Stannah Microlift.

Before using your Microlift, you should read this User Handbook **and** ensure that **all employees are thoroughly trained in both its safe operation and use.**

Your Microlift is a precision product manufactured to the highest quality standards and conforms with all British and European statutory requirements for goods lifts as shown on our 'EC Declaration of Conformity', which has been issued in accordance with the Machinery (Safety) Regulations.

Your Microlift will give you many years of trouble-free operation provided that it is properly maintained and treated with respect. Points to ensure consistent satisfactory service are covered in this handbook. In the unlikely event of difficulty, please read the section on Troubleshooting on page 14 - it could save you the cost of an unnecessary service call.

A 'Lock Release' key will have been left by our installers in the Microlift motor compartment. It is for use by trained lift engineers only - **DO NOT** attempt to use it yourself.

We would remind you as the owner/user of this goods lift that you have certain legal obligations relating to Health & Safety. These are summarised as follows:

**1.** The Provision & Use of Work Equipment Regulations 1998 (PUWER) states "Every employer shall ensure that work equipment is maintained in an efficient state, in efficient working order and in good repair". We strongly recommend that you entrust this to our local Service Centre (address and telephone numbers of our Nationwide Service Network are on page 15). It should be noted that in order to validate any guarantee (see page 13), the Microlift must be serviced within the first three months from handover and thereafter at three monthly intervals.

**2.** The PUWER regulations also state that "Every employer shall ensure that all persons who use work equipment have received adequate training for purposes of Health & Safety". It is therefore your responsibility to ensure that **anyone** who may need to use the lift **not only reads this User Handbook but also receives adequate training.**

**3.** The Lifting Operations & Lifting Equipment Regulations 1998 (LOLER) further require that lifting equipment is thoroughly examined by a competent person. For a Microlift this thorough examination is required every 12 months. Stannah can offer this examination for a small fee and would recommend more regular maintenance to keep your Microlift in tip-top condition.

**4.** The Health & Safety at Work Act 1974 and supporting regulations place a general obligation on both employees and persons in control of premises to provide safe access together with adequate lighting to enable the Stannah Service Engineer to work safely within the Microlift motor compartment.

**5.** You must ensure that the Microlift motor compartment is not used for purposes other than housing the Microlift equipment. Access to the motor compartment must be secure against unauthorised entry: a permanent warning notice has been supplied which must be affixed to the Microlift motor compartment door.

# MICROLIFT OPERATION

## CONTROLS

Microlift controls are located beside the landing shutter doors on each floor that the lift serves. The controls are very simple; each control station contains an individual button for each floor that the lift serves, **Green** being the "call" button for the particular floor you are on and **white** buttons to send the lift to any of the other floors. The **red** indicator is a 'Lift in Use' light.

## CALLING

- If the **green button** is illuminated, the Microlift is at that floor ready to be loaded.
- If a **white button** is illuminated, this indicates that the lift is at another floor. If the **red light** is not illuminated, the Microlift can be called by pressing the **green button** (Fig. 1).
- The **red light** will come on to confirm that the Microlift is on it's way (Fig. 2).
- On arrival the **green button** will illuminate and the **red light** will go out. The arrival buzzer (if fitted) will also sound. This shows the Microlift has arrived and is ready to be loaded (Fig. 3).
- When the landing shutter door is opened, the **red light** will also illuminate to show users on other floor levels that the Microlift is in use (Fig. 4).
- If a **white button** is illuminated, this indicates that the lift is on another floor.
- If the **red light** is illuminated this indicates that the Microlift is not available because the inner car shutter door (if fitted) or landing shutter door is not properly closed.
- If the **red light** stays on, go to the floor indicated by the **white button** and close the landing shutter door and/or the inner car shutter door (if fitted) to put the Microlift back into service.

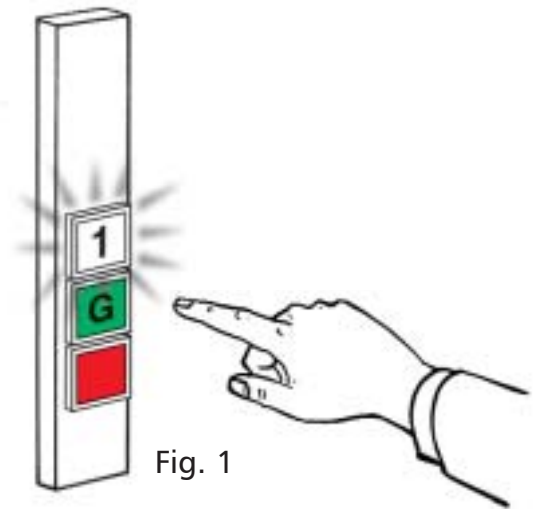

# SAFE OPERATION OF CAR SHUTTER

## Upper Compartment

To open the car shutter safely, first lift the top section until there is a gap of approximately 300mm as shown in Fig. 5.

The **red light** will illuminate to indicate that the Microlift is in use.

To fully open the car shutter, push down on the bottom section until it is level with the lift car floor as shown in Fig. 6.

To close the car shutter, gently lift the bottom section until the two sections meet together as shown in Fig. 7.

### CAUTION:

If this procedure is not followed correctly there may be a risk of injury if the top shutter is opened as shown in Fig. 8.

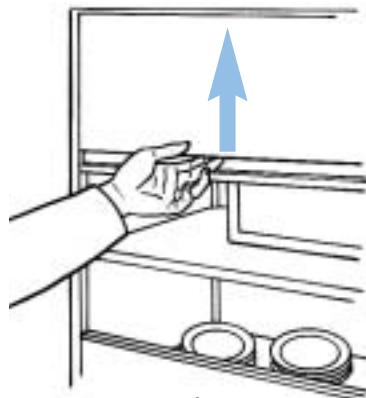

Fig. 5

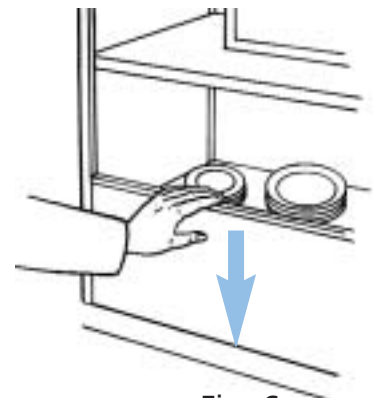

Fig. 6

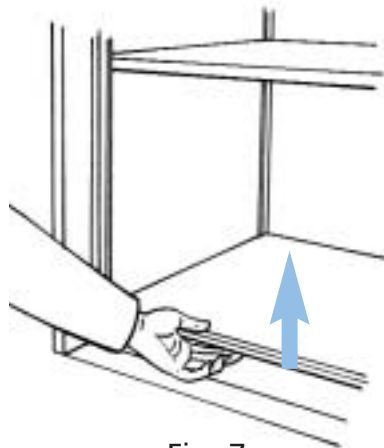

Fig. 7



Fig. 8

## Lower Compartment

To access the lower compartment, pull the handle gently (Fig. 9). The **red light** will illuminate to indicate that the Microlift is in use. Then open the inner car gate (where fitted) by gently pulling the handle from right to left (Fig. 10).

When loading of the lower lift compartment is complete, gently pull the inner car gate closed from left to right (where fitted) using the handle and then finally close the outer landing door.

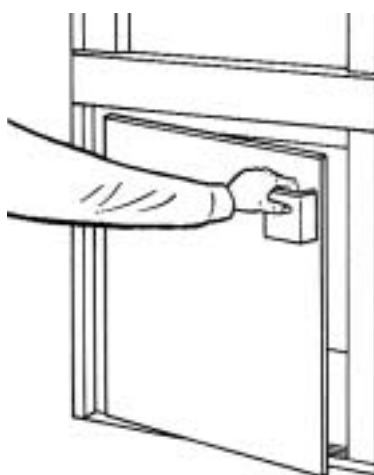

Fig. 9



Fig. 10

**Please note that if either the inner car shutter or gate and/or the outer landing shutter/door is not correctly closed the red light will not go out and the lift will not operate.**

# MICROLIFT OPERATION

## LOADING

When the **green button** is illuminated, the Microlift is at that floor and is ready for loading.

To access the upper lift compartment, open the landing shutter door by lifting up the handle. Then open the inner car shutter door (if fitted) and load the Microlift.

To access the lower compartment, pull gently on the handle. Then open the inner car gate (where fitted) by gently pushing the handle and load the Microlift.

When loading your Microlift you should ensure that:

- the load is secure and that items cannot move or topple (Fig. 11).
- the load does not exceed the carrying capacity of the Microlift (if in doubt, make another trip!) (fig. 12).
- the load does not overhang the edge of the lift car (Fig. 13).
- the shelf is not overloaded (maximum shelf load is 50kg) (Fig. 14).
- when loading of the upper compartment is complete, gently close the inner car shutter door (where fitted) and then close the outer landing shutter door.
- when loading of the lower lift compartment is complete, gently pull the inner car gate closed (where fitted) using the handle and then close the outer landing door.
- the **red light** will go out when the lift is ready to be sent to the desired floor.

Note: The **green light** remains illuminated until the Microlift moves away from your floor.

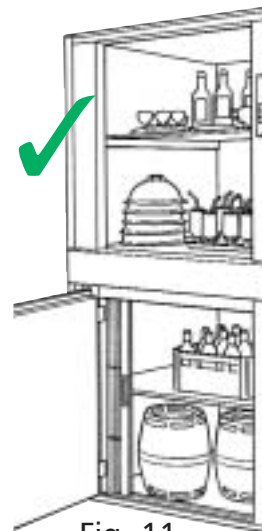

Fig. 11

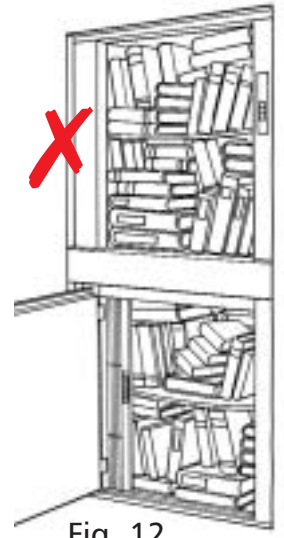

Fig. 12



Fig. 13



Fig. 14

For bulky objects the shelf in the upper lift compartment can be removed as follows:-

- lift up one side of the shelf whilst supporting the other side with your other hand (Fig 15).
- with the shelf at about 45 degrees, move the lower side away from the side wall of the car.
- the shelf can then be withdrawn from the lift car, or laid flat on the lift car floor if desired.



Fig. 15

Note: If your Double Decker Microlift is fitted with a heated shelf option, then **this type of shelf cannot be removed.**

# MICROLIFT OPERATION

## SENDING

- Press the **white button** to send the lift to the desired floor (Fig 16).
- The **green light** will go out and the **red light** will come on to confirm that the Microlift is on its way
- On arrival at the selected floor the **red light** will go out and the green light at that floor will illuminate.
- The Microlift arrival buzzer (if fitted) will sound as the Microlift arrives

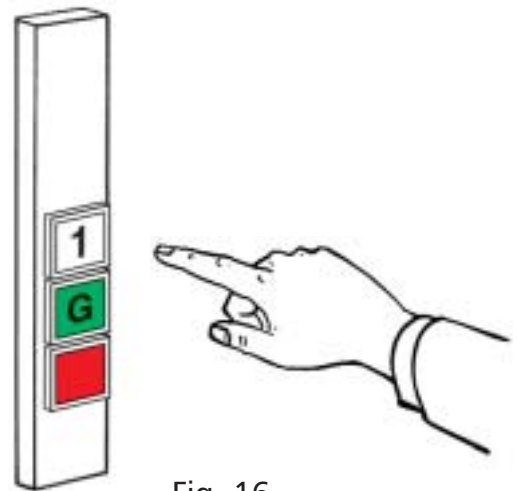

Fig. 16

## UNLOADING

- To unload the upper compartment of the Microlift, open the landing shutter door, followed by the Microlift car shutter door (where fitted) (Fig 17). The **red light** will illuminate to indicate that the Microlift is in use. The upper compartment can now be unloaded.
- To unload the lower compartment of the Microlift, pull gently on the door handle. The **red light** will illuminate to indicate that the Microlift is in use. Gently pull the handle of the inner car gate (where fitted) to gain access to the lower lift compartment (Fig. 18). The lower compartment can now be unloaded.
- When you have finished unloading the Microlift please remember to gently close the car gate/shutter door (where fitted), followed by the landing shutter/door to make sure the Microlift is available to other users (Fig 19).
- The **red light** will go out to confirm that the Microlift is again available for use.
- **Note: Only load or unload one compartment at a time.**

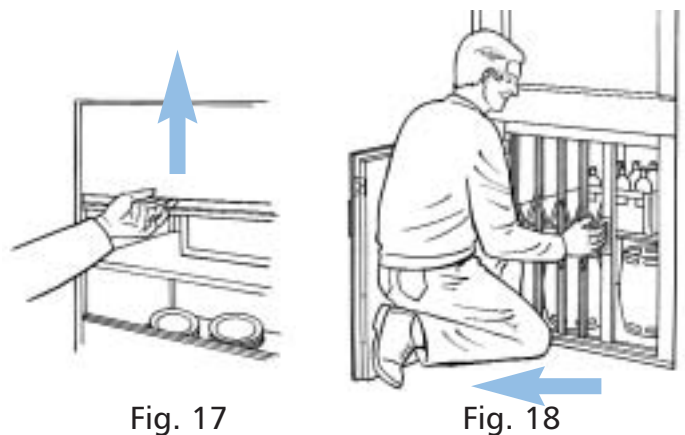

Fig. 17

Fig. 18

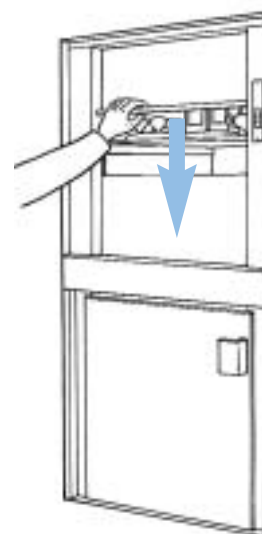

Fig. 19

## GENERAL

- It is not important whether the top or bottom lift compartment is loaded or unloaded first.
- It does not matter if either of the lift compartments is empty whilst the lift is in operation.

# MICROLIFT OPERATION

## DO'S AND DON'TS

**DO** make sure that the load is secure and not overhanging any part of the Microlift car (Fig 20).

**DO** close all doors after unloading (Fig 21).

**DO** report any malfunctions immediately, having first referred to the Troubleshooting guide on page 14 (Fig 22).

**DON'T** slam the shutter door when opening and closing (you will damage the operating mechanism) (Fig 23).

**DON'T** try to prise the shutter open (you will damage the door lock mechanism) (Fig 24).

**DON'T** overload the lift or shelf (Fig 25).

**DON'T** try to enter or ride in the Microlift - it is for carrying goods only (Fig. 26).

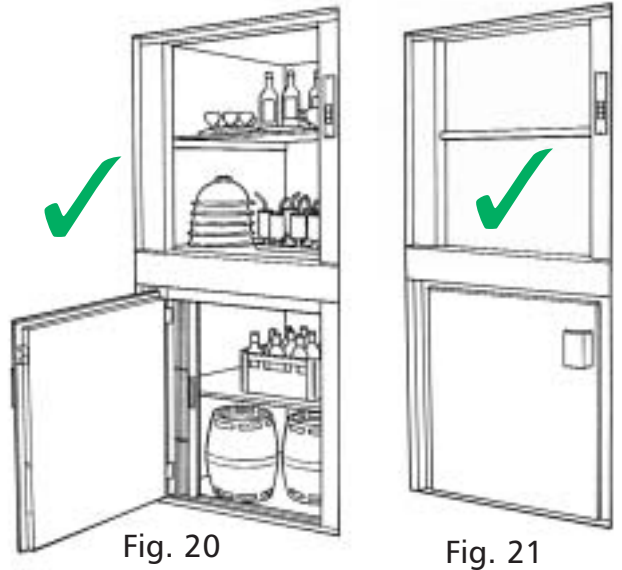

Fig. 20

Fig. 21



Fig. 22



Fig. 23



Fig. 24

**DON'T** allow anyone to open the landing doors or inner car shutter doors of the upper compartment **AT THE SAME TIME** as the lower compartment is being loaded/unloaded. If the top compartment doors are opened, there is the possibility of a striking hazard to anyone working below (Fig. 27).

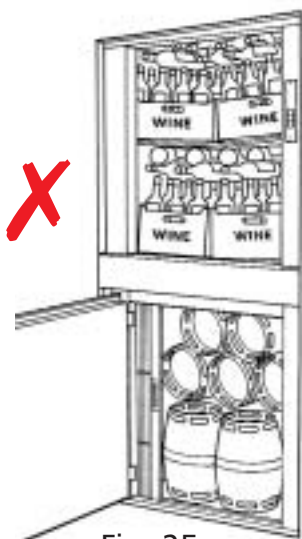

Fig. 25



Fig. 26



Fig. 27

# MICROLIFT INTERCOM OPTION

The following information applies to Microlifts fitted with the intercom option.

## DESCRIPTION

The Microlift intercom option is designed to enable users on different floor levels served by the lift to communicate with each other.

Generally the intercom handset is positioned on the wall next to the Microlift landing entrance at each floor the lift serves. It comprises a wall mounted unit with one or more push buttons (depending on the model of the lift) and a handset (Fig. 28).

## OPERATION

### To make a call - 2 floor Microlift

Lift the handset from the cradle and press the single button on the wall mounted unit (Fig. 29).

### To make a call - 3 floor (or above) Microlift

Lift the handset from its cradle and press the button corresponding to the floor you wish to talk to (Fig. 29).

When the button is pressed an audible sound will be heard from the handset at the other floor. Push the button again if the intercom is not answered.

When the handset is answered at the other floor, simply talk to the other person as you would on a normal telephone. (Fig. 30).

When you have completed your conversation replace the handset into the cradle (Fig. 31).

### To receive a call

If you hear the intercom ringing (Fig. 32).....

Pick up the handset and talk to the other person (Fig. 30).

When you have completed the conversation replace the handset into the cradle (Fig. 31).



Fig. 28



Fig. 29



Fig. 30



Fig. 31



Fig. 32

# MICROLIFT HEATED COMPARTMENT OPTION

The following information applies to Microlifts fitted with the heated compartment option.

## DESCRIPTION

The Microlift heated compartment option is designed for keeping food hot during transportation between floor levels. It should not be used for storing food as it is **NOT designed to be a heated cabinet**. The heating is confined to the upper section of the lift; it has no effect on the lower half, which can still be used for cold drinks (even ice cream!) with the heater on.

A thermostatic temperature controller is fitted to prevent overheating or further cooking of prepared food whilst travelling in the lift.

Your Microlift compartment heater is positioned below the ceiling of the lift car. The heater controls, comprising an On/Off switch and temperature dial, are positioned on the side wall of the lift, just above the shelf (Fig. 33)



Fig. 33

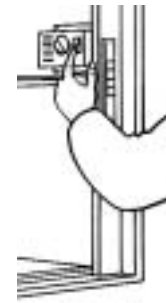

Fig. 34

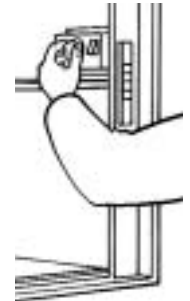

Fig. 35

## OPERATION

To turn the heater on or off, operate the On/Off switch, ensuring there are no combustible materials within the lift (Fig.34). The radiant heating effect is almost instantaneous.

The heater can be left on continuously as the thermostat prevents overheating. However, we recommend that it be turned on only when required.

To adjust the temperature, turn the temperature dial (clockwise for hotter, anti-clockwise for cooler) (Fig. 35).

## PRECAUTIONS

When the heater is on (and for some time after switching off) all surfaces within the upper section of the lift compartment (shelf, walls, roof and top half of the shutter door) will be **HOT TO THE TOUCH**. This is quite normal, but care must be taken to avoid contact with bare skin.

**Heated Compartment Option Only**  
As detailed on page 6, you can see that the shelf can be removed from its normal position. Please ensure that this task is **NOT UNDERTAKEN** when the **SHELF IS HOT**. This operation cannot be undertaken on the heated shelf option.



We strongly recommend that an oven cloth, oven gloves or similar normal standard kitchen heat protectors are **ALWAYS USED** when loading and unloading hot food into and out of the heated section of the lift.

Whenever placing food containers, dishes, plates etc. within the heated section of the lift always ensure that they are **HEAT RESISTANT**.

# MICROLIFT HEATED SHELF OPTION

The following information applies to Microlifts fitted with the heated shelf option.

## DESCRIPTION

The Microlift heated shelf option is designed for keeping food hot during transportation between floor levels. It should not be used for storing food as it is **NOT designed to be a heated cabinet**. Each shelf (if more than one is fitted) is supplied with a heating element - depending on the original specification. The lift floor may also be fitted with a heated element. Each shelf is pre-set to reach a temperature of 40°C.

## OPERATION

To switch the heated shelf/shelves on or off, operate the On/Off switch which is located next to the lift "mains" isolator. The shelf/shelves will take approximately 15 minutes to reach temperature.

If more than one shelf is fitted the shelves CANNOT be independently controlled, so if the switch is switched on all the shelves will heat up.



Microlift with three heated shelves fitted.

**Note: Heated shelves are not removable.**

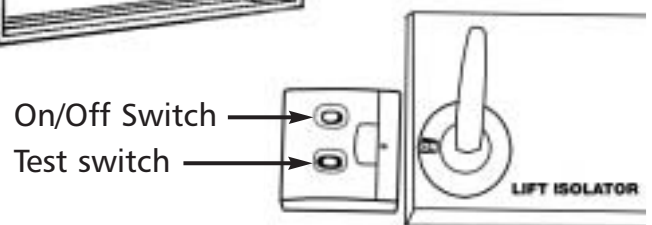

As previously mentioned, the temperature is pre-set and can only be adjusted by a suitably trained person (please contact Stannah if training is required).

The On/Off switch is also a safety RCD. Red-ON, Black-OFF, Green-TEST.

For cleaning information, please see to page 12.



Do not place combustible materials within the lift as this could **INCREASE** the risk of a **POSSIBLE FIRE**.

## CARE

In addition to the care procedures on page 12, take particular care to avoid water getting into the heater controls when cleaning.

## TROUBLESHOOTING

If, after the heater has been switched on, the upper section of the lift remains cold then check:

- that the temperature dial is not set too low (heated compartment option only)
- that the dedicated isolator switch is in the ON position. This is located next to the lift isolator at the top floor that the Microlift serves.

If the heater still fails to work after these checks, call your local Stannah Service Branch (page 15) to investigate for a likely electrical problem.

# MICROLIFT CARE

The following procedures carried out regularly will help to keep your Microlift in first class condition:

## CLEANING

Stainless steel shutters and doors should be cleaned with a soft cloth, using a light oil (e.g. baby oil) and then wiped off with a dry, lint-free cloth.

All other surfaces should be cleaned with a soft cloth and detergent - avoid using excessive amounts of water in either of the lift compartments or on the landing doors.

Never use abrasives for cleaning any of the surfaces on your Microlift.

The lift compartments should be cleaned when the lift is positioned at the lowest floor level.

Cleaning the Microlift compartments can be made easier if the shelf is taken out - see page 6 - this also makes cleaning the shelf easier.

## SPILLAGES

Make sure you mop up and wipe dry any liquid spillages **IMMEDIATELY**.

In the event of a major spillage overflowing into either of the Microlift compartments, contact our Service branch. You will need a Lift Service Engineer to provide you with access to the Microlift pit to enable you to clean up.

## MOTOR COMPARTMENT

Keep the Microlift motor compartment locked at all times to prevent unauthorised access.

**DO NOT** use the motor compartment for any purpose other than the operation of the Microlift.

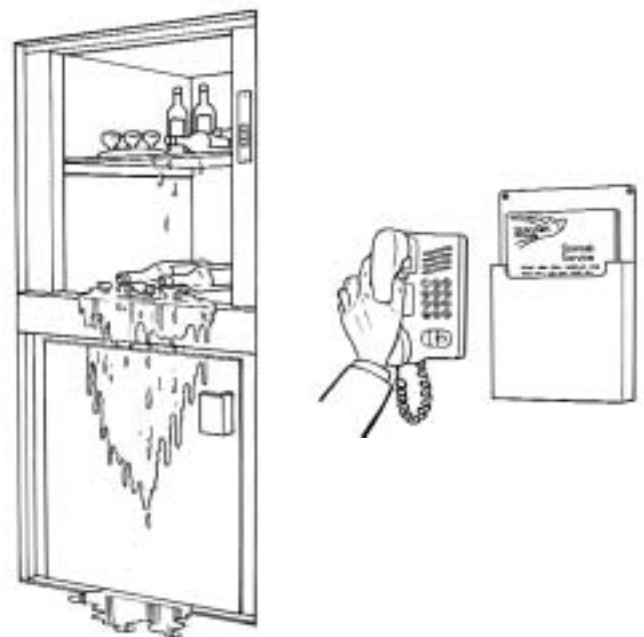
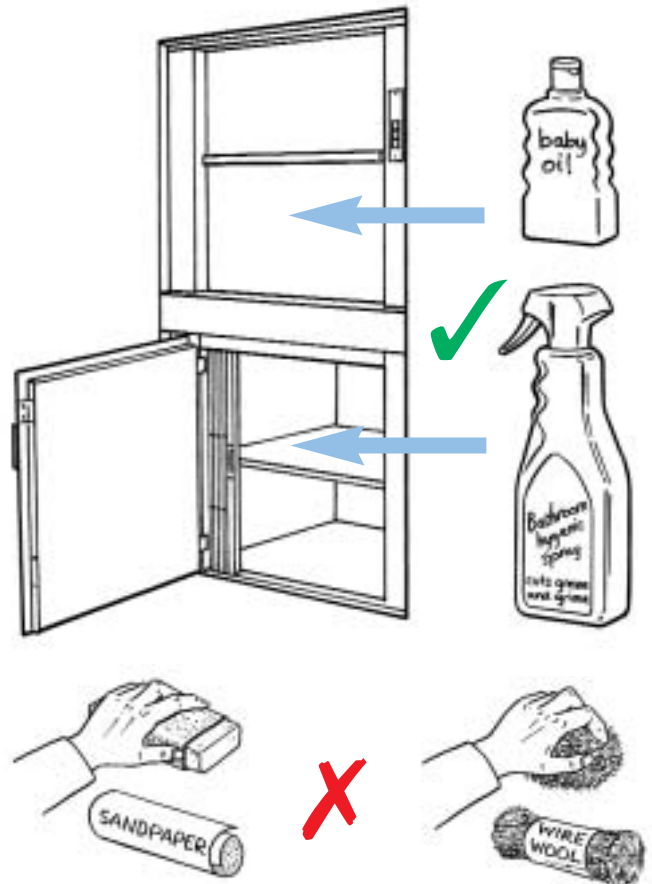

---

# GUARANTEE

---

## YOUR STANNAH GUARANTEE

Stannah Microlifts Ltd are proud to have secured ISO 9001:2000 Quality Management Systems Certification and are pleased to guarantee the whole of our materials and workmanship for a period of twelve months from completion of installation and handover of the lift to you, on the following conditions:

- That you enter into a service contract with our sister company Stannah Lift Services Ltd to ensure that the lift is serviced within the first three months from the date of handover and thereafter at three monthly intervals. As with a motor car, your new lift must be properly serviced and maintained to keep it safe and at it's very best. The Service Contract is included for the first 12 months.
- Should any defective workmanship or materials become evident within the twelve month period, we undertake to repair or replace the defective part, as soon as possible during normal working hours (Monday to Thursday 8.00am to 4.45pm, Friday 8.00am to 3.45pm).
- Should attendance outside normal working hours be requested, it will be subject to a reasonable excess charge. The address and telephone number of your nearest Service Branch is to be found at each lift entrance.
- The Guarantee does not cover repairs, replacements or adjustments which may be required as a result of ordinary wear and tear, wilful or accidental damage, misuse, neglect or any other cause beyond our control.
- If at any time the characteristics or performance of the machine are altered, the machine must be issued with a new EC Declaration of Conformity and a new CE Mark affixed.
- That all outstanding monies have been paid to us.



Stannah Microlifts Ltd  
Caxton Close, East Portway, Andover, Hants, SP10 3QN  
Tel: 01264 351922

# TROUBLESHOOTING

Check this list before contacting your local Stannah Service Branch - it could save you time and the cost of an unnecessary service call.

Problem	Cause	Cure
Lift does not operate and <b>red indicator light</b> remains on.	Lift car and/or landing door left open.	Check all landing and inner car doors are properly closed on all floor levels
	Lift stopped below serving level due to overloading	Call Stannah Service Branch
	Over travel timer tripped due to goods falling from the lift car and causing the lift to jam.	Call Stannah Service Branch
No indicator lights and lift will not operate on push buttons.	Power off	Switch power on
	Overload tripped	Call Stannah Service Branch
	Fuse in isolator blown	Replace 15 Amp fuse(s) in isolator if necessary
	Fuse E1 in controller blown	Call Stannah Service Branch
Lift operates but indicator lights do not operate.	Indicator bulbs blown*	Call Stannah Service Branch
Lift does not stop at serving level	Lift over travelled	Call Stannah Service Branch
	Lift car or balance weight tight in guides	Call Stannah Service Branch
Motor rotates but lift car remains stationary.	Goods fallen from the lift car causing the lift to jam.	Call Stannah Service Branch

\* A blown indicator bulb will not affect the operation of the lift. Please be aware that you will incur a charge if you call out the Stannah Service Branch to replace blown indicator bulbs between service visits. The indicator bulbs will normally be replaced as a matter of routine at the next maintenance/service visit - check with your Service Branch to find out when your next visit is due.

**For your local Stannah Service Branch - see details on page 15**

---

# STANNAH SERVICE BRANCHES

---

## **BIRMINGHAM**

Unit A6,  
Coombswood Way,  
Halesowen  
B62 8BH  
Tel: 0121 559 2260  
Fax: 0121 559 8171

## **BRISTOL**

Unit 1,  
City Business Park,  
Easton Road,  
Bristol,  
Avon  
BS5 0SP  
Tel: 0117 955 9976  
Fax: 0117 955 5993

## **BRACKLEY**

Unit 4,  
Boundary Road,  
Buckingham Road Industrial  
Estate,  
Brackley,  
Northants NN13 7ES  
Tel: 01280 704600  
Fax: 01280 701187

## **CHRISTCHURCH**

6 Ambassador Park Estate,  
Airfield Road,  
Christchurch  
Dorset  
BH23 3TQ  
Tel: 01202 476781  
Fax: 01202 485424

## **CRAYFORD**

Unit 46,  
Acorn Industrial Park,  
Crayford Road,  
Crayford,  
Kent  
DA1 4AL  
Tel: 01322 555777  
Fax: 01322 555444

## **DARTFORD**

Unit 8,  
Swan Business Park,  
Sandpit Road,  
Dartford,  
Kent  
DA1 5ED  
Tel: 01322 287828  
Fax: 01322 222720

## **GATESHEAD**

Wellington Road,  
Dunston,  
Gateshead,  
Tyne & Wear  
NE11 9JL  
Tel: 0191 460 0010  
Fax: 0191 460 1143

## **SCOTLAND**

45 Carlyle Avenue,  
Hillington Industrial Estate,  
Glasgow  
G52 4XX  
Tel: 0141 882 9946  
Fax: 0141 882 7503

## **STOCKPORT**

Unit 12,  
Bamford Business Park,  
Whitehill Industrial Estate,  
Stockport,  
Cheshire  
SK4 1PL  
Tel: 0161 477 3344  
Fax: 0161 477 3377

## **MANSFIELD**

48 Bleakhill Way,  
Mansfield,  
Nottinghamshire  
NG18 5EZ  
Tel: 01623 631010  
Fax: 01623 636182

## **NORWICH**

Unit 27/28,  
Morgan Way,  
Bowthorpe Industrial Estate  
Norwich,  
Norfolk  
NR5 9JJ  
Tel: 01603 748021  
Fax: 01603 743097

## **STANNAH MICROLIFTS DISTRIBUTORS**

### **CHANNEL ISLANDS**

Rob Wilder Lifts Ltd  
Nelson House  
Nelson Avenue  
St Helier  
Jersey JE2 4PD  
Tel: 01534 39515  
Fax: 01534 68846

### **IRELAND**

Olympic Lifts Ltd  
Olympic House  
Lissue Industrial Estate  
Lissue Road  
Lisburn  
Co Antrim BT28 2SU  
Tel: 01280 704600  
Fax: 01280 701187



**Stannah Microlifts Ltd**  
Caxton Close, East Portway, Andover, Hampshire SP10 3QN  
**Tel: 01264 351922**  
**Fax: 01264 333465**



### **NOTE**

Whilst every effort has been used to ensure the clarity and accuracy of this Handbook, we cannot be held responsible for damage or injury resulting from negligence or misuse of this lift equipment.